

Product information

Electric motor No. 60008936

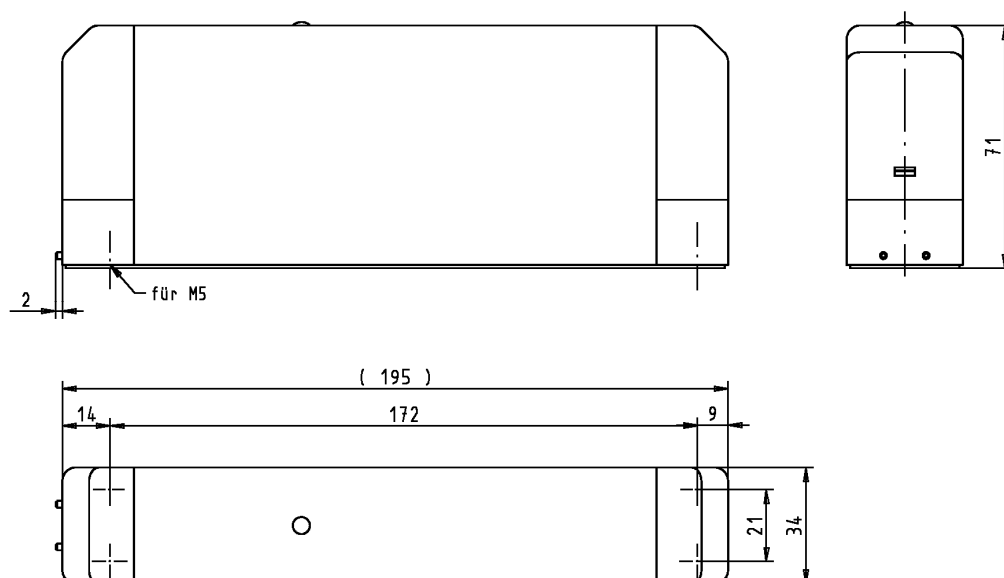

For forced draught and extractor ventilation systems in combination with louvres for concealed action

The motor comprises the following components:

- Maintenance-free electric motor for the operation of ventilation elements (windows, louvres etc.) in indoor ventilation systems.
- The motor is dust / splashproof and corrosion resistant on the outside.
- Structural parts in die cast zinc, anodised aluminium cover (E6/EV1 anodised, optionally plastic coated to RAL), black plastic sealing caps, transmission in sealed die cast zinc housing.
- A load disconnecter switches the motor off automatically at the limit positions and when the load on the mechanism exceeds 1200N.
- A green indicator lamp lights up when the limit position is reached or the load disconnecter cuts in.
- All technical performance features are state-of-the-art. The rating plate is located under the sealing cap.
- 4-pin mains plug for flexible cable (cable customer provided) max. 1.5 mm².
- Cable grip for flexible cable of max. external diameter 7 mm.

Technical data:

Rated voltage	: 230 V AC ±10% / 50 Hz
Current input	: 0.2 A
Power input	: approx. 25 W
Traction and thrust	: max. 1200 N +20%
Locking force	: max. 2000 N
Travel	: max. 70 mm min. approx. 50 mm
Duty type	: S3 60%
Ambient temperature	: -10C° / +60C°
Time for 70 mm travel (under load)	: 50 sec.
Service life	: min. 10000 ventilation cycles at rated load
Parallel connection	: number of motors connected in parallel depends on power supply and control switch.
IP rating	: IP 40 to EN 60529

Not suitable for damp environments

Settings

Important note:

Before the overall system goes into service the travel of the motor or motors must be individually adjusted to the travel of the fitting.

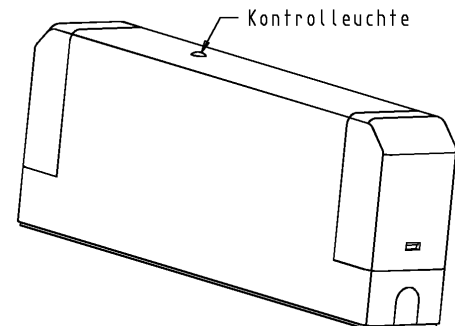

Functional test:

After installation check that the motor reaches its limit positions and is switched off by the load disconnecter. The green indicator lamp should light up.

Travel:

Max. travel 70 mm / can be reduced to approx. 50 mm.

The factory set travel can be changed by inserting a stop on the bottom of the motor.

Notes for window suppliers

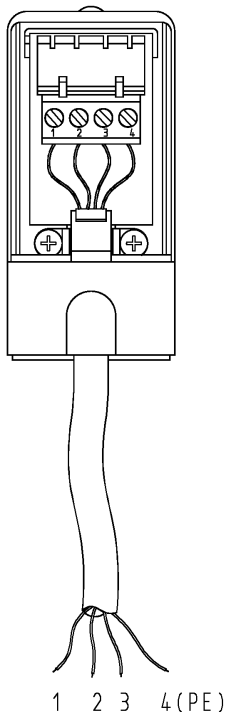

- The motor is designed for the operation of ventilation elements. It must be screwed down using suitable fastenings to a level base in accordance with the relevant installation drawings or on-site conditions.
- **The motor is to be mounted using 4 uniformly tightened retaining screws (M5 DIN 912 cheesehead screws with DIN 7980 spring washers recommended). If the unit is surface mounted the rubber cable gland should be fitted.**
- The motor is to be connected to the fittings using compatible components. Screw travel is normally adjusted to the travel of the fitting on-site. Further steps in installation, setting the direction of screw travel etc., are to be in accordance with the installation and setting instructions specific to the fittings.
- For the functional test on the motor together with the installed louvre window see the wiring instructions below.
- The final wiring (cf. page 3) after on-site installation of the window must be carried out by an approved firm of electricians.
- Adequate lubrication of the connection between the motor and the lever system must be carried out on-site.

Provisional wiring for setting fittings and trial run.

Cores 1 + 2 = Travel nut moves towards plug
Cores 3 + 2 = Travel nut moves towards rating plate

Unused cable cores must be insulated to prevent short-circuit.

(Incorrect installation owing to failure to follow these instructions for settings invalidates the guarantee!)

Product information

The instructions for settings must be followed before the system is connected by the electrician

- ◆ Installation of electrical cables and wiring must be in accordance with VDE regulations.
- ◆ In order to ensure safe and reliable operation, the motor must be connected and operated in accordance with the rating plate and these product information notes.
- ◆ The motor is suitable for both single and group connection.
- ◆ Check over the entire system before connecting to the mains power supply.
- ◆ The motor is fitted with a load disconnecter.
- ◆ Internal safety circuit: in the event of both terminal 1 and 3 being live by mistake, the motor stops. The safety circuit may also be tripped by on-site inductive or capacitive interference voltage which must therefore be eliminated.
- ◆ **In automatically controlled air conditioning and ventilation systems the total service life for the unit is 10000 ventilation cycles.**

Opening the sealing cap to insert the power plug:

Switch off the motor (all-pole disconnection!) before opening the sealing cap (press the locking catch down with a screwdriver and pull the cap off).

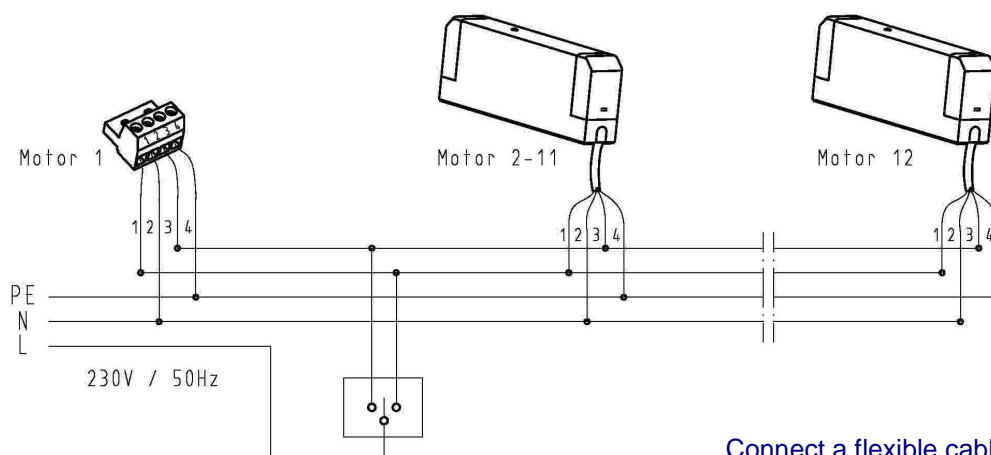
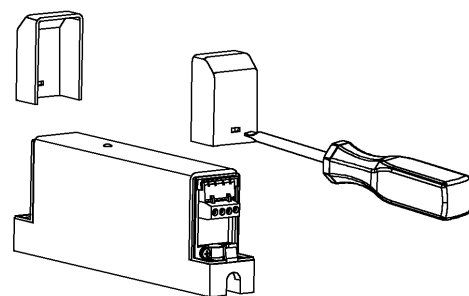

Connect a flexible cable (4x0.75 mm²) to plug numbered 1-2-3-4
 1 = Travel nut moves towards plug
 2 = N
 3 = Travel nut moves towards rating plate
 4 = PE

- After several trial runs check that the motors and retaining screws are still firmly in place.
- Check that all terminals in junction and branching boxes are firmly in place.

Please read the following notes carefully. They provide important information on the safety, installation and proper use of this appliance.

- ❖ The installation and connection of the motor must be carried out by an approved firm of electricians. Electrical connection must be in accordance with VDE and local electricity utility regulations.
- ❖ The motor is not suitable for damp environments!
- ❖ **Accident hazard!** Take appropriate measures to ensure that no-one comes in contact with electrically powered moving parts.
- ❖ Do not attempt to operate a defective appliance.
- ❖ The system must be fully de-energised before any installation, connection or repair work is performed.
- ❖ Any repairs or other work on the appliance must be performed by a qualified service technician.
- ❖ To ensure safe and reliable operation, the motor must be connected and operated in accordance with the rating plate and these product information notes.
- ❖ **Additionally installed concealed arresting mechanisms on tilting windows can prevent damage resulting from improper installation of the motor.**

The manufacturer bears no liability for damage arising from improper use or operation of the appliance.

Warning: Accident Hazard!



If the mechanism opens and closes automatically it is only stopped and de-energised by the load disconnecter.
Take appropriate measures to ensure that no-one comes in contact with electrically powered moving parts! Accident hazard!
The enclosed warning stickers must be stuck on every ventilation element (windows, flaps etc.) at eye level so as to be permanently conspicuous.
The employers' liability insurance regulations on power operated windows, doors and gates must be observed.

Warranty:

Our warranty is in accordance with our General Terms and Conditions of Sale, Delivery and Payment. It does not apply to damage resulting from incorrect electrical connection or improper use of the motor.

Our warranty covers repair or replacement of the appliance at our option in the event of its failure to function or function properly as a result of proven defects in material or manufacture.

Claims for collateral damage or other damages are ruled out.

The appliance should be returned to us carriage free together with a description of the fault.